

Electric towing tractor 25.0 / 30.0 ton

Simai

Four wheel-series

TE250R

TE300R



Electric towing tractor 25.0 ton and 30.0 ton

Truck specifications					TE250R	TE300R
Identification	1.1	Manufacturer			Simai S.p.A	Simai S.p.A
	1.2	Model			TE250R	TE300R
	1.3	Drive			Electric	Electric
	1.4	Operator type			Sit-on	Sit-on
	1.5	Load capacity/rated load ¹⁾	Q	kg	25000	29000 / 34000
	1.7	Rated drawbar pull	F	N	5400	6000
	1.9	Wheelbase	y	mm	2000	2000
Weight	2.1	Service weight		kg	3729	3729
	2.2	Axle load, with load, front/rear		kg	1811 / 2178	1811 / 2178
	2.3	Axle load, without load, front/rear		kg	1721 / 2008	1721 / 2008
Tyres	3.1	Tyre - Cushion(Cu), Extra-elastic(SE), Pneumatic(Pn),Polyurethane			SE/Pn	SE/Pn
	3.2	Tyre - size, front			6.50-10	6.50-10
	3.3	Tyre - size, rear			7.00-12	7.00-12
	3.5	Wheels, number front/rear (x = driven wheels)			2/2X	2/2X
	3.6	Track width, front	b ₁₀	mm	1170	1170
	3.7	Track width, rear	b ₁₁	mm	1190	1190
Dimensions	4.7	Height of cab	h ₆	mm	1900	1900
	4.8	Seat height	h ₇	mm	900	900
	4.12	Coupling height	h ₁₀	mm	310 - 380 - 450 - 520	310 - 380 - 450 - 520
	4.13	Loading height, unloaded	h ₁₁	mm	1060	1060
	4.16	Length of loading surface	l ₃	mm	500	500
	4.17	Overhang	l ₅	mm	545	545
	4.18	Width of loading surface	b ₉	mm	1180	1180
	4.19	Overall length	l ₁	mm	2970	2970
	4.21	Overall width	b ₁	mm	1370	1370
	4.32	Ground clearance, centre of wheelbase	m ₂	mm	200	200
	4.35	Turning radius	W _a	mm	3210	3210
4.36	Internal turning radius	b ₁₃	mm	1500	1500	
Performance data	5.1	Travel speed, with/without load		km/h	12 / 25	12 / 25
	5.6	Max. drawbar pull		N	20000	19000
	5.7	Gradeability		%	see chart	see chart
	5.8	Max. gradeability loaded/unloaded		%	see chart	see chart
	5.10	Service / parking brake (I=Hydraulic E=Electromagnetic M=Mechanical)			I / M	I / M
Electric motor	6.1	Drive motor rating S2 60 min		kW	20	20
	6.4	Battery voltage, nominal capacity ²⁾	K ₅	V/Ah	80/ 500 - 560 - 620	80/ 500 - 560 - 620
	6.5	Battery weight		kg	1300 - 1430 - 1565	1300 - 1430 - 1565
	6.6	Energy consumption according to VDI cycle ³⁾		kWh/h		
Others	8.1	Electronics control			Inverter AC	Inverter AC
	8.4	Sound level at driver's ear according to EN 12053		dB(A)	69	69

¹⁾ Loading surface capacity: 100 kg

²⁾ Performances and weight are intended with 560 Ah battery.

³⁾ Contact the supplier for information.

As per VDI guidelines 2198, this datasheet applies to standard electric tractor / platform truck only.

Dimensions are not binding and can be changed in any moment. The performances must be intended for brand new machines, after having completed the running-in tested in San Donato Milanese factory in normal climatic conditions.

Performances and weight are to be intended with standard motors and battery and with pneumatic tires.

Some data can vary according to different equipments.

Towed weight

READING EXAMPLE:
 CHARGE = 4 TONS
 GRADIENT = 10 %
 DRAWBAR PULL = 10.000 N
 SPEED = 8 Km/h
 MAX PRACTICABLE RAMP LENGTH = 1800 m

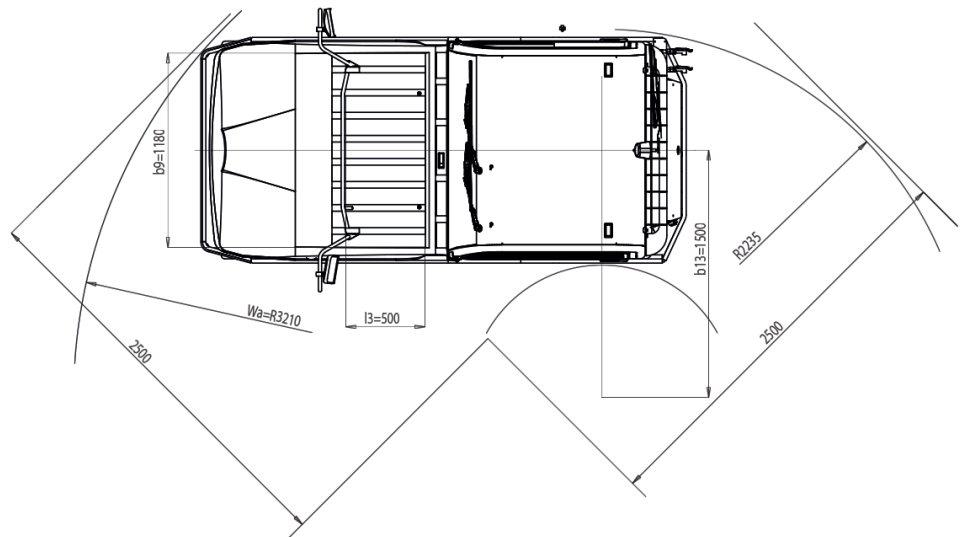
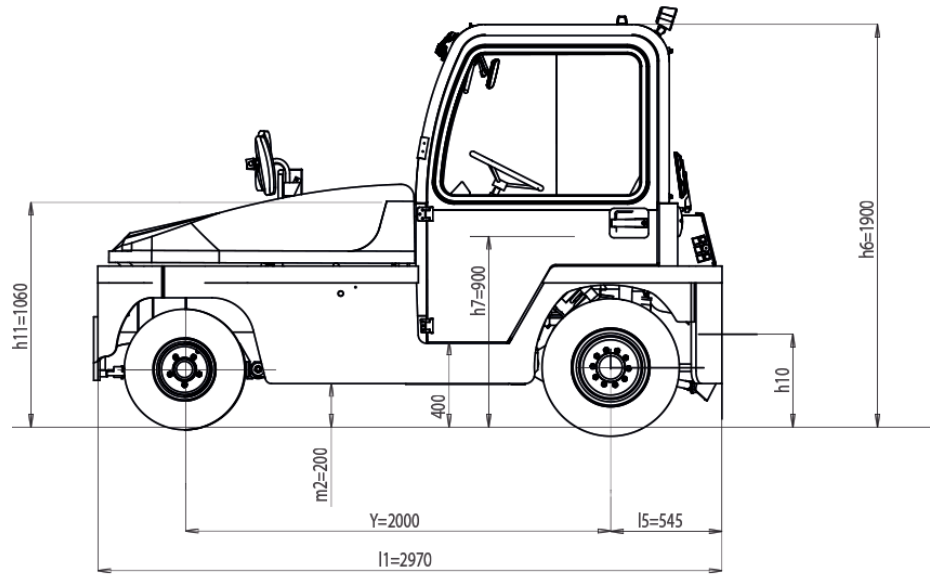
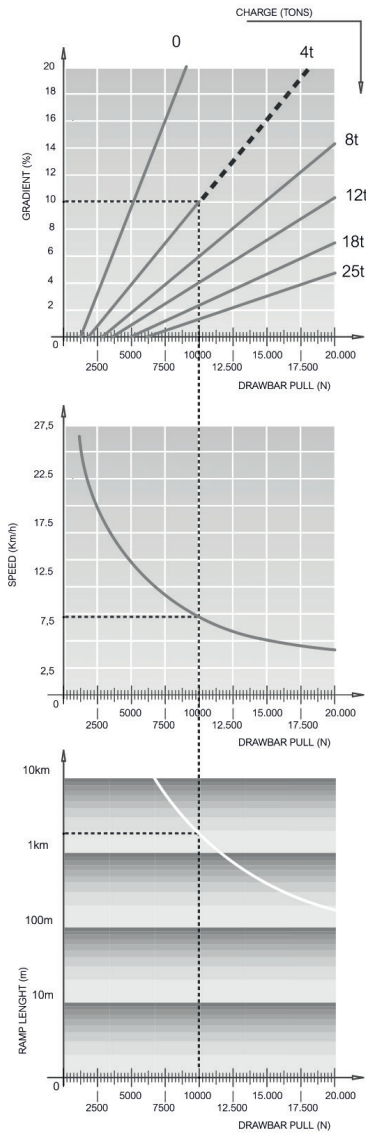

Standard equipments:

- Inching buttons
- Operator presence system
- AC power system
- Pneumatic tyres
- Rear drawbar
- Mechanical parking brake
- Regenerative braking
- Head and tail lights, turn signal lights
- Digital display
- Front platform

