

Electric powered forklift 48V 1.5 - 2.0 ton

TRAIGO

3 wheel

TRAIGO



TRAIGO.i



Electric powered forklift 1.5 - 1.6 t

Truck specifications					9FBE15T	9FBEK16T	9FBE16T	60-9FBEK16T	
Identification	1.1	Manufacturer			Toyota	Toyota	Toyota	Toyota	
	1.2	Model			9FBE15T	9FBEK16T	9FBE16T	60-9FBEK16T	
	1.3	Drive			Electric	Electric	Electric	Electric	
	1.4	Operator type			Rider seated	Rider seated	Rider seated	Rider seated	
	1.5	Load capacity/rated load	Q	kg	1500	1600	1600	1600	
	1.6	Load centre	c	mm	500	500	500	500	
	1.8	Load distance, centre of drive axle to fork	x	mm	317	317	317	317	
	1.9	Wheelbase	y	mm	1305	1413	1521	1413	
	Weight	2.1	Service weight		kg	2974	3009	2985	3095
2.2		Axle load, with load, front/rear		kg	3907/567	4061/548	4037/548	3836/542	
2.3		Axle load, without load, front/rear		kg	1468/1506	1536/1473	1578/1407	1311/1467	
Tyres	3.1	Tyre - pneumatic (P), pneumatic shaped cushion (SE), solid rubber (R)			SE	SE	SE	SE	
	3.2	Tyre size, front			18x7-8	18x7-8	18x7-8	18x7-8	
	3.3	Tyre size, rear			15x4.1/2x8	15x4.1/2x8	15x4.1/2x8	15x4.1/2x8	
	3.5	Wheels, number front/rear (x = driven wheels)			2x/2	2x/2	2x/2	2x/2	
	3.6	Track width, front	b ₁₀	mm	905	905	905	905	
	3.7	Track width, rear	b ₁₁	mm	185	185	185	185	
	Dimensions	4.1	Tilt of mast/fork carriage forward/backward		α/β	deg	5/7	5/7	5/7
4.2		Height, mast lowered		h ₁	mm	2120	2120	2120	
4.3		Free lift		h ₂	mm	115	115	115	
4.4		Lift		h ₃	mm	3300	3300	3300	3300
		Lift height		h ₂₃	mm	3335	3335	3335	3335
4.5		Height, mast extended		h ₄	mm	3870	3870	3870	
4.7		Height of overhead guard (cab)		h ₆	mm	2055	2055	2055	
4.8		Seat height/stand height		h ₇	mm	1065	1065	1065	
4.12		Coupling height		h ₁₀	mm	550	550	550	
4.19		Overall length		l ₁	mm	2772	2880	2988	2880
4.20		Length to face of forks		l ₂	mm	1772	1880	1988	1880
4.21		Overall width		b ₁	mm	1060	1060	1060	1060
4.22		Fork dimensions		s/e/l	mm	35/100/1000	35/100/1000	35/100/1000	35/100/1000
4.23		Fork carriage DIN 15 173, class/type A, B				IIA	IIA	IIA	IIA
4.24		Fork-carriage width		b ₃	mm	920	920	920	920
4.31		Ground clearance, with load, below mast		m ₁	mm	80	80	80	80
4.32		Ground clearance, centre of wheelbase		m ₂	mm	81	81	81	93
4.33		Aisle width for pallets 1000x1200 crossways		A _{st}	mm	3102	3210	3318	3210
4.34		Aisle width for pallets 800x1200 lengthways		A _{st}	mm	3223	3331	3440	3331
4.35		Turning radius		W _a	mm	1455	1563	1671	1563
4.36	Internal turning radius		b ₁₃	mm	0	0	0	0	
Performance data	5.1	Travel speed, with/without load			km/h	16/16	16/16	16/16	16/16
	5.2	Lift speed, with/without load Standard Performance			m/s	0,45/0,61 0,54/0,75	0,43/0,61 0,54/0,75	0,43/0,61 0,54/0,75	0,43/0,61 0,54/0,75
	5.3	Lowering speed, with/without load			m/s	0,58/0,57	0,58/0,57	0,58/0,57	0,58/0,57
	5.5	Drawbar pull, with/without load S2-60'			N	6966	6982	6982	7656
	5.6	Max. drawbar pull, with/without load			N	12237	12266	12266	13450
	5.7	Gradeability, with/without load			%	17,6/28	17/27,7	17,1/28	20,1/34,1
	5.8	Max. gradeability, with/without load			%	24,9/40,3	24,1/39,8	24,3/40,2	28,6/38,2
	5.9	Acceleration time, with/without load			s	4,5/4,1	4,6/4,2	4,6/4,2	4,6/4,2
	5.10	Service brake				Hydraulic	Hydraulic	Hydraulic	Hydraulic
	Electric motor	6.1	Drive motor rating S2 60 min			kW	6,6 x 2	6,6 x 2	6,6 x 2
6.2		Lift motor rating S3 15% Standard Performance			kW	11 12,5	11 12,5	11 12,5	11 12,5
6.3		Battery acc. to DIN 43 531/35/36 A, B, C, no				43 531A	43 531A	43 531A	no
6.4		Battery voltage, nominal capacity K ₅			V/Ah	48/420-460-500	48/525-575-625	48/630-690-750	48/300-420
6.5		Battery weight			kg	708	856	1013	240
6.6		Energy consumption acc. to EN16796 Standard			kWh/h	3,5	3,7	3,6	3,6
6.6		Energy consumption acc. to EN16796 Performance			kWh/h	3,3	3,6	3,4	3,6
Other	8.1	Type of drive control				inverter MOSFET	inverter MOSFET	inverter MOSFET	inverter MOSFET
	8.2	Operating pressure for attachments			bar	183	183	183	183
	8.3	Oil volume for attachments			l/min	42	42	42	42
	8.4	Sound level at the driver's ear according to EN12053			dB(A)	65,8	65,8	65,8	65,8

All data are based on table configuration. Other configurations may give other values.

Truck performance and dimensions are nominal and subject to tolerances.

Products and specifications are subject to change without notice.

Mast dimensions and rated capacities

Model			V								FV				FW				FSV						FSW							
9FBE15T/9FBEK16T /60-9FBEK16T	Lift height	h_{23}	3035	3335	3535	3735	4035	4535	5035	3035	3335	3535	3735	3035	3335	3535	3735	4335	4535	4735	5035	5535	6035	4335	4535	4735	5035	5535	6035	6535	7035	7535
	Lift	h_3	3000	3300	3500	3700	4000	4500	5000	3000	3300	3500	3700	3000	3300	3500	3700	4300	4500	4700	5000	5500	6000	4300	4500	4700	5000	5500	6000	6500	7000	7500
	Height, mast lowered	h_1	1970	2120	2220	2380	2570	2820	3070	1970	2120	2220	2380	2000	2150	2250	2350	1970	2040	2120	2220	2380	2570	1980	2050	2150	2250	2350	2600	2800	3000	3200
	Height, mast extended ¹⁾	h_4	3570	3870	4070	4270	4570	5070	5570	3580	3880	4080	4280	3555	3855	4055	4255	4845	5045	5245	5545	6045	6545	4845	5045	5245	5545	6045	6545	7045	7545	8045
	Height, mast extended ²⁾	h_4	4220	4520	4720	4920	5220	5270	6220	4220	4520	4720	4920	4220	4520	4720	4920	5520	5720	5920	6220	6720	7220	5520	5720	5920	6220	6720	7220	7720	8220	8720
	Free lift, without load backrest	h_2	80	80	80	80	80	80	80	1430	1580	1680	1840	1440	1590	1690	1790	1460	1530	1610	1710	1870	2060	1430	1500	1600	1700	1900	2050	2250	2450	2650
Free lift, with load backrest	h_2	80	80	80	80	80	80	80	750	900	1000	1160	780	930	1030	1130	750	820	900	1000	1160	1350	760	830	930	1030	1230	1380	1580	1780	1980	

1) Without load backrest

2) With load backrest; Height of standard load backrest is 1220 mm.

Pneumatic shaped cushion tyre			V								FV				FW				FSV						FSW								
9FBE15T	Tilt range, forward	deg	5	5	5	5	5	5	5	5	5	5	5	5	5	5	5	5	5	5	5	5	5	5	5	5	5	5	5	5	5		
	Tilt range, backward	deg	7(5)	7(5)	7(5)	7(5)	7(5)	7(5)	7(5)	7(5)	7(5)	7(5)	7(5)	7(5)	7(5)	7(5)	7(5)	7(5)	7(5)	7(5)	7(5)	7(5)	7(5)	7(5)	7(5)	7(5)	7(5)	7(5)	7(5)	7(5)	7(5)		
	Load capacity at 500 mm LC	kg	1500	1500	1500	1500	1500	1500	1500	1500	1500	1500	1500	1500	1500	1500	1500	1500	1500	1500	1500	1500	1450	1100	1500	1500	1500	1500	1375	1300	900	700	525
9FBE16T	Tilt range, forward	deg	5	5	5	5	5	5	5	5	5	5	5	5	5	5	5	5	5	5	5	5	5	5	5	5	5	5	5	5	5		
	Tilt range, backward	deg	7(5)	7(5)	7(5)	7(5)	7(5)	7(5)	7(5)	7(5)	7(5)	7(5)	7(5)	7(5)	7(5)	7(5)	7(5)	7(5)	7(5)	7(5)	7(5)	7(5)	7(5)	7(5)	7(5)	7(5)	7(5)	7(5)	7(5)	7(5)	7(5)		
	Load capacity at 500 mm LC	kg	1600	1600	1600	1600	1600	1600	1600	1600	1600	1600	1600	1600	1600	1600	1600	1600	1600	1600	1600	1600	1585	1450	950	1600	1600	1600	1600	1510	1350	1050	750
9FBE16T 60-9FBEK16T	Tilt range, forward	deg	5	5	5	5	5	5	5	5	5	5	5	5	5	5	5	5	5	5	5	5	5	5	5	5	5	5	5	5	5		
	Tilt range, backward	deg	7(5)	7(5)	7(5)	7(5)	7(5)	7(5)	7(5)	7(5)	7(5)	7(5)	7(5)	7(5)	7(5)	7(5)	7(5)	7(5)	7(5)	7(5)	7(5)	7(5)	7(5)	7(5)	7(5)	7(5)	7(5)	7(5)	7(5)	7(5)	7(5)		
	Load capacity at 500 mm LC	kg	1600	1600	1600	1600	1600	1600	1600	1600	1600	1600	1600	1600	1600	1600	1600	1600	1600	1600	1600	1600	1600	1200	1600	1600	1600	1600	1600	1500	1175	875	650

Data in () are for when "Cabin Series" is selected (minimum front windshield).

TRAIGO

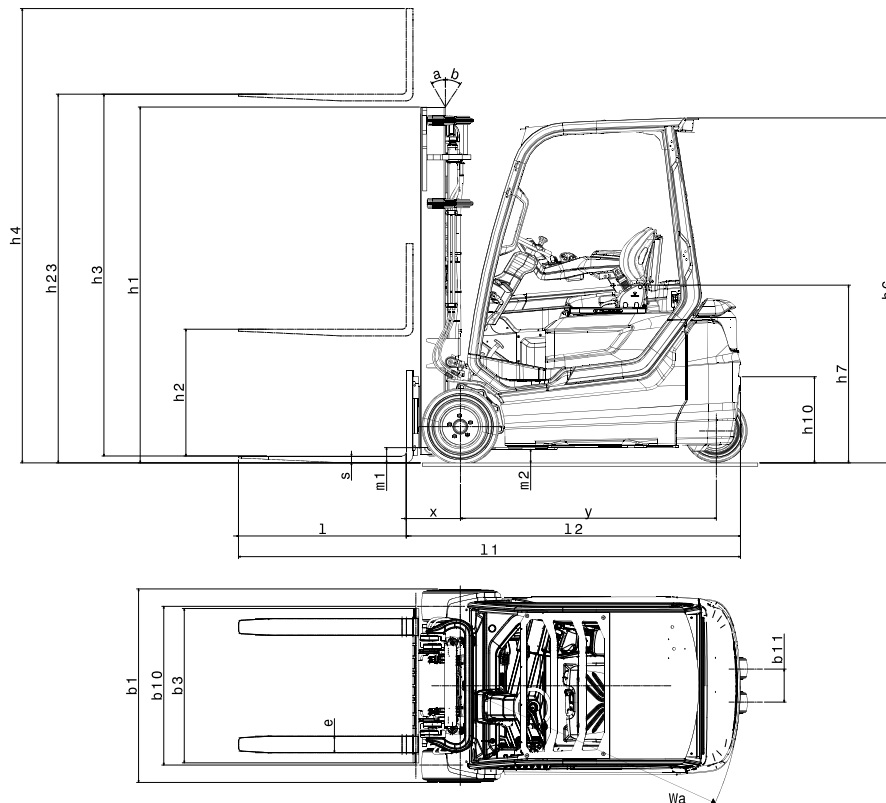

Electric powered forklift 1.8 t

Truck specifications					9FBEK18T	9FBE18T
Identification	1.1	Manufacturer			Toyota	Toyota
	1.2	Model			9FBEK18T	9FBE18T
	1.3	Drive			Electric	Electric
	1.4	Operator type			Rider seated	Rider seated
	1.5	Load capacity/rated load	Q	kg	1800	1800
	1.6	Load centre	c	mm	500	500
	1.8	Load distance, centre of drive axle to fork	x	mm	317	317
	1.9	Wheelbase	Y	mm	1413	1521
	Weight	2.1	Service weight			3134
2.2		Axle load, with load, front/rear			4301/583	4351/558
2.3		Axle load, without load, front/rear			1540/1594	1584/1525
Tyres	3.1	Tyre - pneumatic (P), pneumatic shaped cushion (SE), solid rubber (R)			SE	SE
	3.2	Tyre size, front			18x7-8	18x7-8
	3.3	Tyre size, rear			140/55-9	140/55-9
	3.5	Wheels, number front/rear (x = driven wheels)			2x2	2x2
	3.6	Track width, front	b ₁₀	mm	905	905
	3.7	Track width, rear	b ₁₁	mm	193	193
	Dimensions	4.1	Tilt of mast/fork carriage forward/backward	α/β	deg	5/7
4.2		Height, mast lowered	h ₁	mm	2120	2120
4.3		Free lift	h ₂	mm	115	115
4.4		Lift	h ₃	mm	3300	3300
		Lift height	h ₂₃	mm	3335	3335
4.5		Height, mast extended	h ₄	mm	3870	3870
4.7		Height of overhead guard (cab)	h ₆	mm	2055	2055
4.8		Seat height/stand height	h ₇	mm	1065	1065
4.12		Coupling height	h ₁₀	mm	550	550
4.19		Overall length	l ₁	mm	2880	2988
4.20		Length to face of forks	l ₂	mm	1880	1988
4.21		Overall width	b ₁	mm	1060	1060
4.22		Fork dimensions	s/e/l	mm	35/100/1000	35/100/1000
4.23		Fork carriage DIN 15 173, class/type A, B			IIA	IIA
4.24		Fork-carriage width	b ₃	mm	920	920
4.31		Ground clearance, with load, below mast	m ₁	mm	80	80
4.32		Ground clearance, centre of wheelbase	m ₂	mm	81	81
4.33		Aisle width for pallets 1000x1200 crossways	A _{st}	mm	3210	3318
4.34		Aisle width for pallets 800x1200 lengthways	A _{st}	mm	3331	3440
4.35		Turning radius	W _a	mm	1563	1671
4.36	Internal turning radius	b ₁₃	mm	0	0	
Performance data	5.1	Travel speed, with/without load		km/h	16/16	16/16
	5.2	Lift speed, with/without load Standard Performance		m/s	0,42/0,61 0,52/0,75	0,42/0,61 0,52/0,75
	5.3	Lowering speed, with/without load		m/s	0,58/0,57	0,58/0,57
	5.5	Drawbar pull, with/without load		N	7016	7016
	5.6	Max. drawbar pull, with/without load		N	12325	12325
	5.7	Gradeability, with/without load		%	15,8/26,6	15,9/26,8
	5.8	Max. gradeability, with/without load		%	22,5/38,2	22,6/38,5
	5.9	Acceleration time, with/without load		s	4,7/4,3	4,7/4,3
	5.10	Service brake			Hydraulic	Hydraulic
	Electric motor	6.1	Drive motor rating S2 60 min		kW	6,6 x 2
6.2		Lift motor rating S3 15% Standard Performance		kW	11 12,5	11 12,5
6.3		Battery acc. to DIN 43 531/35/36 A, B, C, no			43 531A	43 531A
6.4		Battery voltage, nominal capacity K ₅		V/Ah	48/525-575-625	48/630-690-750
6.5		Battery weight		kg	856	1013
6.6		Energy consumption acc. to EN16796 Standard		kWh/h	3,8	3,8
6.6		Energy consumption acc. to EN16796 Performance		kWh/h	3,6	3,6
Other	8.1	Type of drive control			inverter MOSFET	inverter MOSFET
	8.2	Operating pressure for attachments		bar	183	183
	8.3	Oil volume for attachments		l/min	42	42
	8.4	Sound level at the driver's ear according to EN 12 053		dB(A)	65,8	65,8

All data are based on table configuration. Other configurations may give other values.

Truck performance and dimensions are nominal and subject to tolerances.

Products and specifications are subject to change without notice.

Mast dimensions and rated capacities

Model			V								FV				FW				FSV						FSW							
9FBEK18T/9FBE18T	Lift height	h_{23}	3035	3335	3535	3735	4035	4535	5035	3035	3335	3535	3735	3035	3335	3535	3735	4335	4535	4735	5035	5535	6035	4335	4535	4735	5035	5535	6035	6535	7035	7535
	Lift	h_3	3000	3300	3500	3700	4000	4500	5000	3000	3300	3500	3700	3000	3300	3500	3700	4300	4500	4700	5000	5500	6000	4300	4500	4700	5000	5500	6000	6500	7000	7500
	Height, mast lowered	h_1	1970	2120	2220	2380	2570	2820	3070	1970	2120	2220	2380	2000	2150	2250	2350	1970	2040	2120	2220	2380	2570	1980	2050	2150	2250	2350	2600	2800	3000	3200
	Height, mast extended ¹⁾	h_4	3570	3870	4070	4270	4570	5070	5570	3580	3880	4080	4280	3555	3855	4055	4255	4845	5045	5245	5545	6045	6545	4845	5045	5245	5545	6045	6545	7045	7545	8045
	Height, mast extended ²⁾	h_4	4220	4520	4720	4920	5220	5270	6220	4220	4520	4720	4920	4220	4520	4720	4920	5520	5720	5920	6220	6720	7220	5520	5720	5920	6220	6720	7220	7720	8220	8720
	Free lift, without load backrest	h_2	80	80	80	80	80	80	80	1430	1580	1680	1840	1440	1590	1690	1790	1460	1530	1610	1710	1870	2060	1430	1500	1600	1700	1900	2050	2250	2450	2650
Free lift, with load backrest	h_2	80	80	80	80	80	80	80	750	900	1000	1160	780	930	1030	1130	750	820	900	1000	1160	1350	760	830	930	1030	1230	1380	1580	1780	1980	

1) Without load backrest

2) With load backrest: Height of standard load backrest is 1220 mm.

Pneumatic shaped cushion tyre			V								FV				FW				FSV						FSW							
9FBEK18T	Tilt range, forward	deg	5	5	5	5	5	5	5	5	5	5	5	5	5	5	5	5	5	5	5	5	5	5	5	5	5	5	5	5	5	
	Tilt range, backward	deg	7(5)	7(5)	7(5)	7(5)	7(5)	7(5)	7(5)	7(5)	7(5)	7(5)	7(5)	7(5)	7(5)	7(5)	7(5)	7(5)	7(5)	7(5)	7(5)	5	5	7(5)	7(5)	7(5)	7(5)	7(5)	5	5	5	5
	Load capacity at 500 mm LC	kg	1800	1800	1800	1800	1800	1800	1800	1800	1800	1800	1800	1800	1800	1800	1800	1800	1800	1800	1800	1650	1500	1125	1800	1800	1800	1800	1550	1400	1050	800
9FBE18T	Tilt range, forward	deg	5	5	5	5	5	5	5	5	5	5	5	5	5	5	5	5	5	5	5	5	5	5	5	5	5	5	5	5	5	
	Tilt range, backward	deg	7(5)	7(5)	7(5)	7(5)	7(5)	7(5)	7(5)	7(5)	7(5)	7(5)	7(5)	7(5)	7(5)	7(5)	7(5)	7(5)	7(5)	7(5)	7(5)	5	5	7(5)	7(5)	7(5)	7(5)	7(5)	5	5	5	7(5)
	Load capacity at 500 mm LC	kg	1800	1800	1800	1800	1800	1800	1800	1800	1800	1800	1800	1800	1800	1800	1800	1800	1800	1800	1800	1500	1200	1800	1800	1800	1800	1630	1500	1200	890	700

Data in () are for when "Cabin Series" is selected (minimum front windshield).

TRAIGO

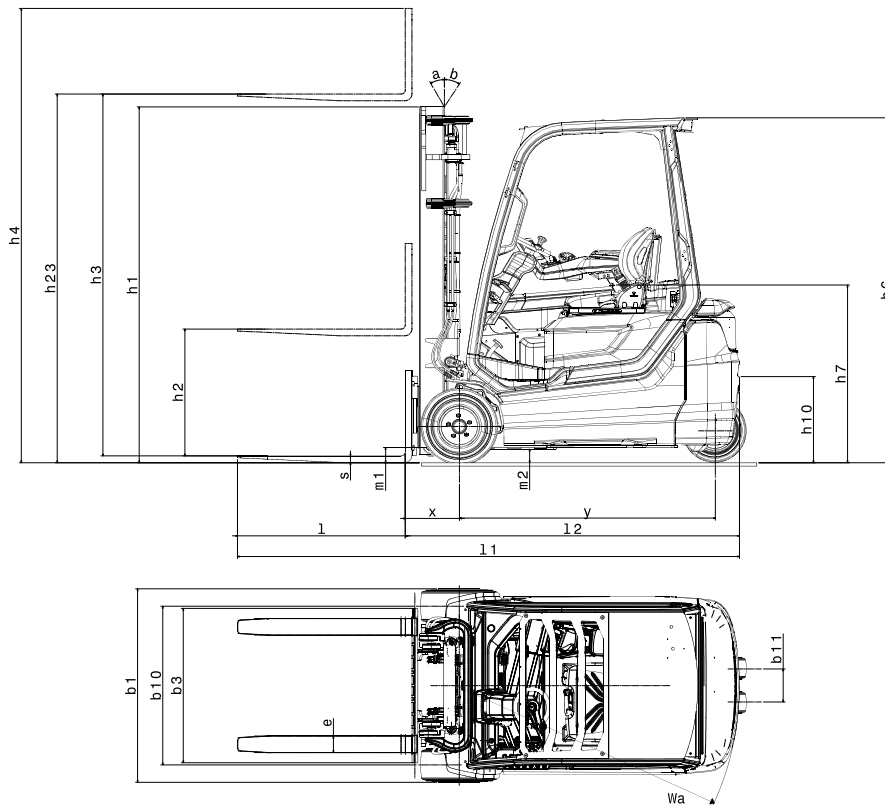

Electric powered forklift 2.0 t

Truck specifications					9FBE20T	60-9FBE20T
Identification	1.1	Manufacturer			Toyota	Toyota
	1.2	Model			9FBE20T	60-9FBE20T
	1.3	Drive			Electric	Electric
	1.4	Operator type			Rider seated	Rider seated
	1.5	Load capacity/rated load	Q	kg	2000	2000
	1.6	Load centre	c	mm	500	500
	1.8	Load distance, centre of drive axle to fork	x	mm	317	317
	1.9	Wheelbase	y	mm	1521	1521
	Weight	2.1	Service weight			3312
2.2		Axle load, with load, front/rear			4715/597	4478/617
2.3		Axle load, without load, front/rear			1640/1672	1372/1723
Tyres	3.1	Tyre - pneumatic (P), pneumatic shaped cushion (SE), solid rubber (R)			SE	SE
	3.2	Tyre size, front			200/50-10	200/50-10
	3.3	Tyre size, rear			140/55-9	140/55-9
	3.5	Wheels, number front/rear (x = driven wheels)			2x2	2x2
	3.6	Track width, front	b ₁₀	mm	946	946
	3.7	Track width, rear	b ₁₁	mm	193	193
	Dimensions	4.1	Tilt of mast/fork carriage forward/backward			α/β deg
4.2		Height, mast lowered			h ₁ mm	2120
4.3		Free lift			h ₂ mm	115
4.4		Lift			h ₃ mm	3300
		Lift height			h ₂₃ mm	3335
4.5		Height, mast extended			h ₄ mm	3870
4.7		Height of overhead guard (cab)			h ₆ mm	2055
4.8		Seat height/stand height			h ₇ mm	1065
4.12		Coupling height			h ₁₀ mm	550
4.19		Overall length			l ₁ mm	2988
4.20		Length to face of forks			l ₂ mm	1988
4.21		Overall width			b ₁ mm	1152
4.22		Fork dimensions			s/e/l mm	35/120/1000
4.23		Fork carriage DIN 15 173, class/type A, B				IIA
4.24		Fork-carriage width			b ₃ mm	920
4.31		Ground clearance, with load, below mast			m ₁ mm	90
4.32		Ground clearance, centre of wheelbase			m ₂ mm	81
4.33		Aisle width for pallets 1000x1200 crossways			A _{st} mm	3318
4.34		Aisle width for pallets 800x1200 lengthways			A _{st} mm	3440
4.35		Turning radius			W _a mm	1671
4.36	Internal turning radius			b ₁₃ mm	0	
Performance data	5.1	Travel speed, with/without load			km/h	16/16
	5.2	Lift speed, with/without load Standard Performance			m/s	0,38/0,54 0,44/0,64
	5.3	Lowering speed, with/without load			m/s	0,52/0,5
	5.5	Drawbar pull, with/without load			N	6757
	5.6	Max. drawbar pull, with/without load			N	11872
	5.7	Gradeability, with/without load			%	14/24,1
	5.8	Max. gradeability, with/without load			%	19,9/34,4
	5.9	Acceleration time, with/without load			s	4,7/4,3
	5.10	Service brake				Hydraulic
	Electric motor	6.1	Drive motor rating S2 60 min			kW
6.2		Lift motor rating S3 15% Standard Performance			kW	11 12,5
6.3		Battery acc. to DIN 43 531/35/36 A, B, C, no				43 531A
6.4		Battery voltage, nominal capacity K ₅			V/Ah	48/630-690-750
6.5		Battery weight			kg	1013
6.6		Energy consumption acc. to EN16796 Standard			kWh/h	3,9
6.6		Energy consumption acc. to EN16796 Performance			kWh/h	3,7
Other	8.1	Type of drive control				Inverter MOSFET
	8.2	Operating pressure for attachments			bar	183
	8.3	Oil volume for attachments			l/min	42
	8.4	Sound level at the driver's ear according to EN12053			dB(A)	65,8

All data are based on table configuration. Other configurations may give other values.

Truck performance and dimensions are nominal and subject to tolerances.

Products and specifications are subject to change without notice.

Mast dimensions and rated capacities

Model			V								FV				FW				FSV						FSW							
9FBZ0T/60-9FBZ0T	Lift height	h_{23}	3035	3335	3535	3735	4035	4535	5035	3035	3335	3535	3735	3035	3335	3535	3735	4335	4535	4735	5035	5535	6035	4335	4535	4735	5035	5535	6035	6535	7035	7535
	Lift	h_3	3000	3300	3500	3700	4000	4500	5000	3000	3300	3500	3700	3000	3300	3500	3700	4300	4500	4700	5000	5500	6000	4300	4500	4700	5000	5500	6000	6500	7000	7500
	Height, mast lowered	h_1	1970	2120	2220	2380	2570	2820	3070	1970	2120	2220	2380	2000	2150	2250	2350	1970	2040	2120	2220	2380	2570	1980	2050	2150	2250	2350	2600	2800	3000	3200
	Height, mast extended ¹⁾	h_4	3570	3870	4070	4270	4570	5070	5570	3580	3880	4080	4280	3555	3855	4055	4255	4845	5045	5245	5545	6045	6545	4845	5045	5245	5545	6045	6545	7045	7545	8045
	Height, mast extended ²⁾	h_4	4220	4520	4720	4920	5220	5270	6220	4220	4520	4720	4920	4220	4520	4720	4920	5520	5720	5920	6220	6720	7220	5520	5720	5920	6220	6720	7220	7720	8220	8720
	Free lift, without load backrest	h_2	80	80	80	80	80	80	80	1430	1580	1680	1840	1440	1590	1690	1790	1460	1530	1610	1710	1870	2060	1430	1500	1600	1700	1900	2050	2250	2450	2650
Free lift, with load backrest	h_2	80	80	80	80	80	80	80	750	900	1000	1160	780	930	1030	1130	750	820	900	1000	1160	1350	760	830	930	1030	1230	1380	1580	1780	1980	

1) Without load backrest

2) With load backrest: Height of standard load backrest is 1220 mm.

Pneumatic shaped cushion tyre			V								FV				FW				FSV						FSW							
9FBZ0T/60-9FBZ0T	Tilt range, forward	deg	5	5	5	5	5	5	5	5	5	5	5	5	5	5	5	5	5	5	5	5	5	5	5	5	5	5	5	5	5	
	Tilt range, backward	deg	7(5)	7(5)	7(5)	7(5)	7(5)	7(5)	7(5)	7(5)	7(5)	7(5)	7(5)	7(5)	7(5)	7(5)	7(5)	7(5)	7(5)	7(5)	7(5)	5	5	7(5)	7(5)	7(5)	7(5)	7(5)	5	5	5	5
	Load capacity at 500 mm LC	kg	2000	2000	2000	2000	2000	2000	1900	2000	2000	2000	2000	2000	2000	2000	2000	1950	1950	1900	1800	1650	1525	1950	1950	1900	1900	1900	1800	1250	950	750
60-9FBZ0T	Tilt range, forward	deg	5	5	5	5	5	5	5	5	5	5	5	5	5	5	5	5	5	5	5	5	5	5	5	5	5	5	5	5	5	
	Tilt range, backward	deg	7(5)	7(5)	7(5)	7(5)	7(5)	7(5)	7(5)	7(5)	7(5)	7(5)	7(5)	7(5)	7(5)	7(5)	7(5)	7(5)	7(5)	7(5)	7(5)	5	5	7(5)	7(5)	7(5)	7(5)	7(5)	5	5	5	5
	Load capacity at 500 mm LC	kg	2000	2000	2000	2000	2000	2000	1900	2000	2000	2000	2000	2000	2000	2000	2000	1950	1950	1900	1800	1650	1530	1950	1950	1900	1900	1900	1800	1370	1050	750

Data in () are for when "Cabin Series" is selected (minimum front windshield).

TRAIGO*.i*

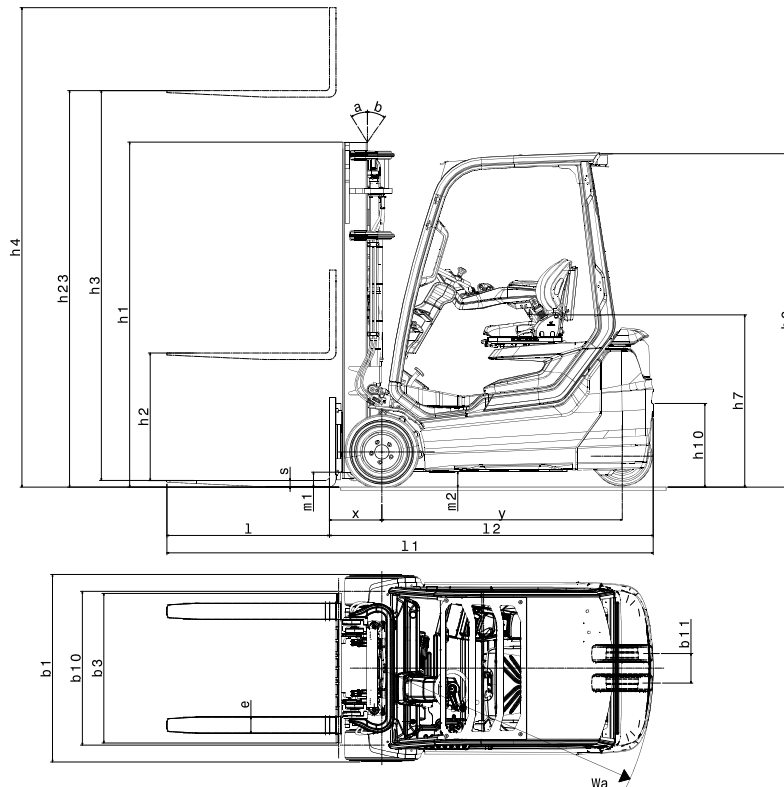

Standard equipments:

- Toyota SAS (System of Active Stability)
- SyncoDrive from Toyota
- Wet disc brakes
- Automatic parking brake
- Electric new design steering and telescopic column
- Operator presence sensing system (OPS)
- Toyota ORS seat (Operator Restraint System)
- Seat mounted minilevers
- Wide visible mast (V3300 mm)
- Long forks (length:1000 mm)
- Long forkbar (length: 920 mm)
- 3 way valves (A400)
- Narrow brake pedal
- Pneumatic shaped cushion tyres
- Digital Multifunction display with wheel indicator
- Adjustable tilt steering column
- Full floating driver's compartment
- Shockless landing lift
- Seatbelt lock recognition linked with OPS
- Orange seatbelt
- Battery door opening sensor (not available for 60-models)
- Remaining operating time indicator on main display



TMHE-Toyota Material Handling Europe, version 2, 2025-03-27

TOYOTA

MATERIAL HANDLING